

# DPS Series



**Stainless Steel, Splash-Proof, Multipurpose Scales!**



**DPS-1212**



**DPS-2015**

by **Yamato**

# DIGITAL PLATFORM SCALE

## DPS Series

### Splash-Proof Easy to Read

#### Application

The Yamato DPS Series is a tough and versatile line of scales. The splash-proof, stainless steel construction of the indicator housing, column and platform make the DPS Series perfect for use in food related, shipping, receiving and many other applications. The DPS Series also features a total weightment accumulator and counter, and a full function numeric keypad ideal for key-in tares. It will keep track of the total weight of the product, up to 9999 pounds, and the total number of products weighed.

#### Features

- ◆ Fluorescent tube display
- ◆ Keypad set over/under
- ◆ Net/Gross weighing
- ◆ Push-button and preset tare
- ◆ Push-button zero reset
- ◆ Automatic zero tracking
- ◆ Center-of-zero indicator
- ◆ Automatic/manual total weight accumulation
- ◆ USDA accepted
- ◆ NTEP approved indicator

#### Options

- ◆ Display column
- ◆ Other platform sizes and capacities available upon request

### Stainless Steel Platform Legal for Trade Models

#### Specifications

Model	DPS-1212	DPS-2015
<b>Certificate of Conformance</b>	Indicator: 96-016 Base: 99-028	96-016 N/A
<b>Accuracy Class</b>	Class III, 3200 Divisions	
<b>Capacity and Divisions</b>	<div style="border: 1px solid black; padding: 5px; display: inline-block;"> <b>Legal for Trade</b> </div> <ul style="list-style-type: none"> <li>64 lb x 0.02 lb</li> <li>32 lb x 0.01 lb</li> <li>64 kg x 0.02 kg</li> <li>32 kg x 0.01 kg</li> <li>16 kg x 0.005 kg</li> </ul>	<ul style="list-style-type: none"> <li>320 lb x 0.1 lb</li> <li>160 lb x 0.05 lb</li> <li>64 lb x 0.02 lb</li> <li>160 kg x 0.05 kg</li> <li>64 kg x 0.02 kg</li> <li>32 kg x 0.01 kg</li> </ul>
	<ul style="list-style-type: none"> <li>16 lb x 0.005 lb</li> <li>6.4 lb x 0.002 lb</li> <li>6.4 kg x 0.002 kg</li> <li>3.2 kg x 0.001 kg</li> </ul>	
<b>Weighing System</b>	Strain Gage Load Cell	
<b>Platform</b>	12" x 12" 305 mm x 305 mm	20" x 15" 508 mm x 381 mm Stainless Steel
<b>Indicator</b>	0.8" fluorescent tube	
<b>Power Supply</b>	110/115 VAC, 50/60Hz, 15A	
<b>Operating Temperature</b>	14°F to 104°F (-10 C to 40 C)	
<b>Shipping Weight</b>	33 lb (15 kg)	51 lb (23 kg)

All dimensions are approximate. Dimensions are given in inches (millimeters.)

#### Dimensions

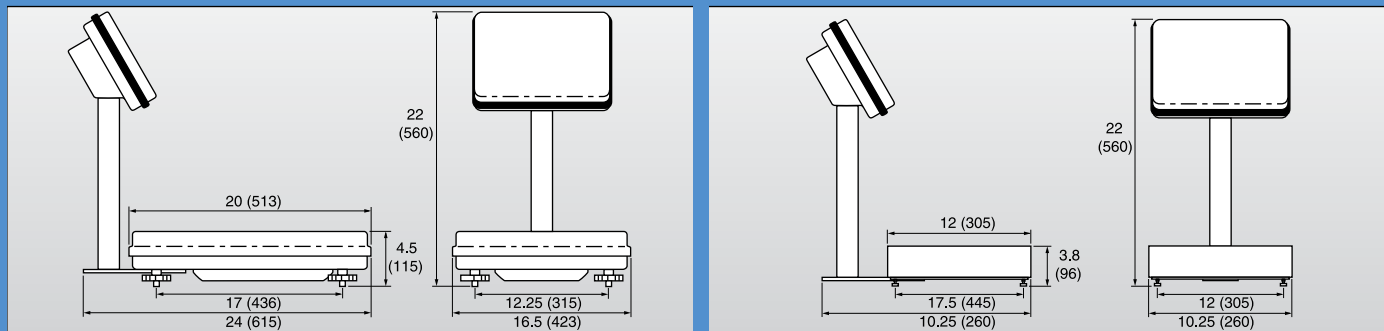

# Yamato

WWW.YamatoCorp.com

**Yamato Corporation**  
P.O. Box 15070  
Colorado Springs, CO 80935-5070  
U.S.A.  
Tel (719) 591-1500  
Fax (719) 591-1045

**Yamato Tech Corporation**  
#112-19425 Langley By-Pass  
Surrey, B.C. V3S 6K1  
Canada  
Tel (604) 533-2338  
Fax (604) 533-0827

YCO-1043-01-00 Printed in U.S.A.