



Semi-Automatic Divider/Rounders

LVO offers the widest selection of top quality divider/rounders in the industry. This broad selection of models, coupled with their more gentle rounding action, enables you to produce a great deal more than the regular line of buns and rolls. Now you can include such products as:

- Portuguese Rolls (Choose a model to 4 ounces or higher)
- Airy French Rolls (Ideal with the 20- or 30-part model)
- Flour Tortillas (Get more production with a 50-part machine)
- Miniature Breads or Individual Sized Pizza (Choose from a 7- or 15-part divider unit)

LVO divider/rounders are also ideal for only dividing doughs for pies, tarts and specialty rolls.

Considering their versatility, reliable performance, and superior construction, LVO divider/rounders are the most durable and the best choice for a wide range of operations including retail artisan, or in-store bakeries, restaurants, pizza shops, hotels or commissaries, hospitals, college or prison food facilities.

LVO machines take away the laborious task of dividing and rounding doughs by hand, making the entire process faster, easier, and simpler. Better yet, you'll be assured of uniformity in dough weight and shape, time after time. What's more, the quick release design of the front and rear covers and embracing ring make cleaning quick and easy.

In addition to the LVO semi-automatic divider/rounder we offer AUTOMAT models and the IH Series with the unique removable head assembly, giving you unparalleled production versatility. (Ask for our comprehensive four-color brochure to obtain more details.)



Visit us on the web at
www.lvomfg.com.

Meeting UL, NSF,
and CSA Standards



LVO Semi-automatic Divider/Rounders

TECHNICAL SPECIFICATIONS:

FEATURES:

- Three light weight, sanitary plastic rounding plates are included
- Machine is shipped with necessary oil for rounding mechanism
- Cutting knives are hot tin plated for sanitary purposes
- 2 years parts and labor warranty
- Easy weight adjustment
- No oil in, or above, product zone
- Minimum maintenance required
- Rounding mechanism runs in oil bath for absolute smooth, quiet and long lasting operation
- Hourly production of up to 7,000 pieces (depends on operator efficiency and production flow)

CONSTRUCTION:

- Base, gear housing, arch, and knife frame made of sturdy cast iron
- Finish is a lead-free enamel paint
- Head covers in front and rear are of durable thermoplastic material, impact resistant and shatter proof; they snap off and on for fast cleaning
- Rounding plate drive is via a double bearing support
- Head can be tilted to left or right side for easy cleaning; dough embracing ring comes off in seconds

ELECTRICAL:

- Manual motor start with built-in thermal overload protector
- On/off switch for motor on left side base panel
- Machine comes with 12 foot main cable
- Electrical requirements: 220 volts, 3 phase, 60 cycles; 3/4 HP motor, 3.0 amps, 0.55 KW

APPROVALS:

- ETL listed to meet UL, NSF, and CSA standards
- BISSC (Baking Industry Sanitation Standard Committee) approved

OPTIONS:

- 1-phase version, 60 cycles, 220 volts available
- 50 cycle machines and other voltages also available on request
- Machine on wheels
- Stainless steel knives and aluminum head assembly

In an effort to continuously improve our products, the company reserves the right to change specifications and dimensions without notice. Dough capacities are approximate and depend on dough consistency.

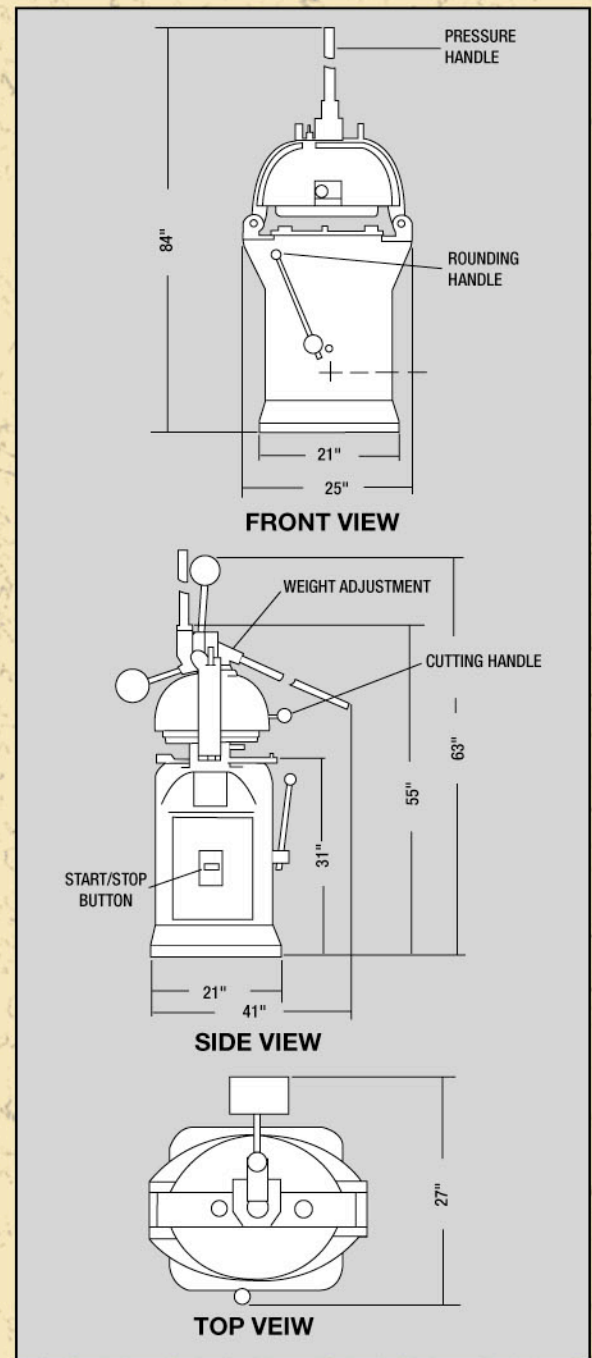

Models	Capacities			Weights		Crate Dimensions DxWxH
	Semi-automatic Machines	Number of parts	Weight of individual dough pieces - in ounces	Total Weight range in lbs.	Net lbs.	
361	36	0.7 - 2.5	1.5 - 5.6	770	880	31"x33"x63"
362	36	0.9 - 3.3	2.0 - 7.5	770	880	31"x33"x63"
363	36	1.0 - 4.0	2.3 - 9.0	770	880	31"x33"x63"
301	30	1.4 - 4.3	2.6 - 8.1	770	880	31"x33"x63"
501	50	0.6 - 1.5	1.9 - 4.7	770	880	31"x33"x63"
151	15	5.4 - 9.5	5.1 - 8.9	770	880	31"x33"x63"
201	20	2.5 - 7.1	3.9 - 8.4	770	880	31"x33"x63"
071	7	9.0 - 21.0	3.9 - 9.2	770	880	31"x33"x63"

* Manufacturer reserves the right to change specs with out notice.



LVO MANUFACTURING INC.

P.O. BOX 188, 808 N 2ND AVENUE E, ROCK RAPIDS IOWA 51246
 712/472-3734 OR 712/472-3735, FAX 712-472-2203, TOLL FREE 1-800-346-5749
 VISIT US ON THE WEB AT www.lvomfg.com.