



Item No. _____
 Project _____
 Quantity _____

BakerSeries Spiral Mixers

MODEL: FBM - Series



Model FBM-120 shown

PRODUCTION CAPACITY GUIDE

Model/Capacity	Kilogram	Lbs Flour	Lbs Dough	Bags
FBM-25	25	27.5	55	(25#) 1
FBM-50	50	55	110	(50#) 1
FBM-80	80	110	166	(50#) 2
FBM-120	120	165	264	(50#) 3
FBM-200	200	250	440	(50#) 5

Note: Capacities based on 60/40 water to flour ratio

SHORT BID SPECIFICATION:

Spiral Mixer shall be a Lang Bakery Equipment Co. Model FBM____ [Insert: model no.] Fixed Bowl Mixer, with heavy gauge stainless steel bowl and dough hook. Dough Hook(s) shall be cylindrical in cross section with a "J" type end to reach the center of the bowl and shall have an average bowl clearance of 3/16 inch and shall not contact the bowl at any time. Bowl shall have solid stainless steel top ring, fully welded to the bowl and polished. Bowl shall be fitted with Polyethylene upper bowl guide rollers with sealed ball bearings. Mixer shall be built with heavy gauge, welded, rigid steel frame box and head. Mixer shall be fitted with a heavy wrot stainless steel (not cast) dough-ball breaker bar, affixed to the head by four (4) stainless steel bolts. Mixer shall have digital timer and speed indicator and be operable in both timer and manual control. Mixer shall have 2 forward dough hook speeds (not variable speed) and shall have independent reversible bowl and hook drive motor drive system, including dual stage, non-slip. Low noise-high torque belt drive system. Mixer shall have four (4) cushioned adjustable feet mounted external to the base, one forward swivel caster and two rear fixed wheels mounted under the base. Mixer shall have safety-interlocked guard with ingredient opening to prevent operator injury. Mixer shall have controls and emergency stop button mounted at eye level on the front side. Mixer shall be ETL listed as meeting UL 763 and NSF-8.

STANDARD PRODUCT WARRANTY

One-Year Parts, 90 days Labor (US Including Alaska and Hawaii, Canada)

CONSTRUCTION FEATURES

- Heavy gauge stainless steel bowl with dual bowl
- "J" Type dough hook for rapid incorporation
- Cylindrical Hook w/ 3/16" clearance for rapid development
- Heavy duty dough breaker bar
- Solid stainless steel bowl top roll
- Heavy gauge steel frame box with rigid torsion-tube design
- Rigid head section and bearing box
- High torque, dual stage, non-slip quiet belt drive
- Three-point caster system for easy cleaning
- Screw-down cushioned feet for stability
- P208-240 VAC 3-phase drive and bowl motors
- Ingredient fill opening in front of cover
- Interlocking, PVC bowl cover and hook guard
- Extra heavy bowl drive and bearing system

PERFORMANCE FEATURES

- High Torque, dual-stage belt drive
- 2 speed, reversible dough hook drive motor
- Reversible bowl drive motor for quick incorporation
- Dual stage, non-slip, silent belt drive system
- Dual upper bowl guide bearings

CONTROL FEATURES

- 2 speed reversible, dual reduction motor drive system
- Reversible dual reduction bowl drive system
- 60 minute timer with auto speed change
- Manual back-up control system
- Emergency stop button
- Controls mounted on the front for easy access
- Automatic over-current protection
- 6' electrical supply cord with NEMA cord cap



Meets UL 763 and NSF-8

Sheet Number FBM-RR1 (rev 10/05)



BakerSeries Spiral Dough Mixer

MODEL: FBM - Series

INSTALLATION REQUIREMENT

- FBM-25, 208-240 VAC, 50-60 Hz. 3 Phase, 15 Amp Circuit, receptacle type NEMA L15-20
- FBM-50, 208-240 VAC, 50-60 Hz. 3 Phase, 20 Amp Circuit, receptacle type NEMA L15-20
- FBM-80, 208-240 VAC, 50-60 Hz. 3 Phase, 25 Amp Circuit, receptacle type NEMA L15-30
- FBM-120, 208-240 VAC, 50-60 Hz. 3 Phase, 40 Amp Circuit, receptacle type 5745 AN
- FBM-200, 208-240 VAC, 50-60 Hz. 3 Phase, 50 Amp Circuit, receptacle type 5745 AN

OPTIONS & ACCESSORIES

- Polyethylene drain plug in mixing bowl
- Removable bowl for FBM-120 and FBM-200

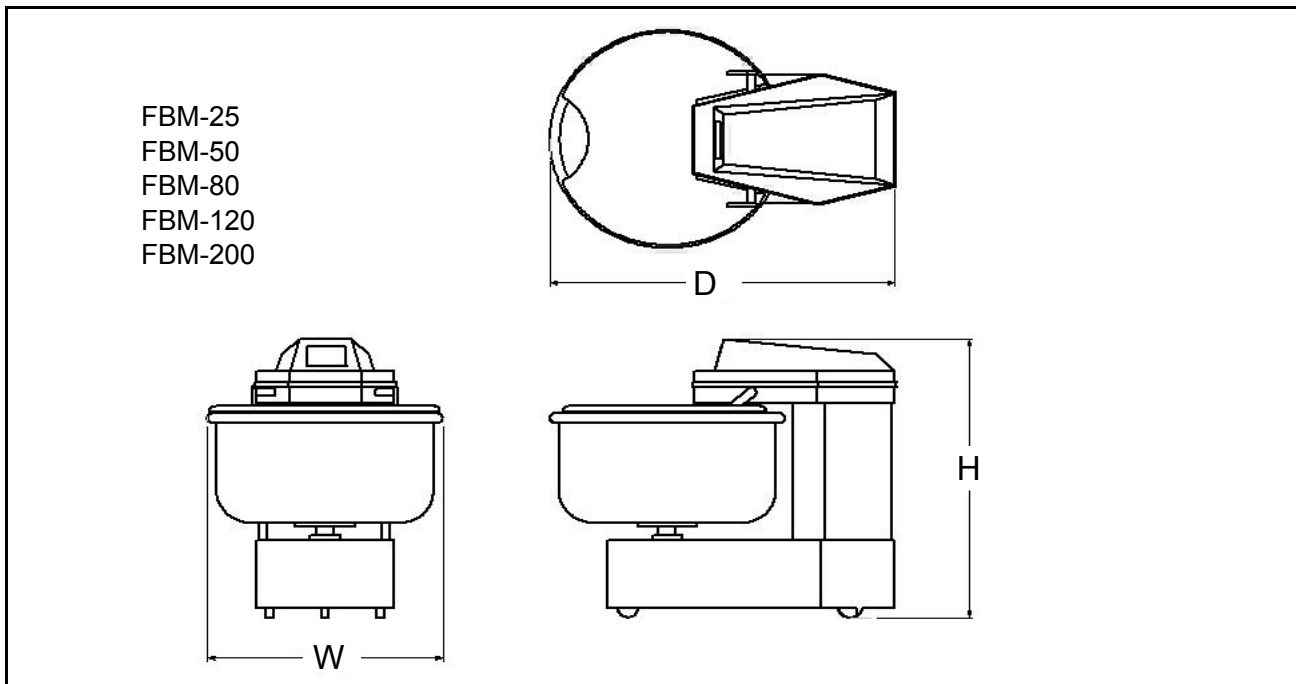

Model	Dimensions Height x Width x Depth	Clearance for Operations			Weight		Freight Class
		Rear	LH Side	RH Side	Actual	Shipping	
FBM-25	42" x 20" x 34"	6"	1"	1"	400	450	85
FBM-50	47" x 22" x 37"	6"	1"	1"	675	712	85
FBM-80	51" x 30" x 45"	6"	1"	1"	900	1014	85
FBM-120	52" x 33" x 52"	6"	1"	1"	1125	1300	85
FBM-200	62" x 39" x 63"	6"	1"	1"	1900	2500	85

Electrical Specifications By Model											
Voltage	Phase	FBM-25		FBM-50		FBM-80		FBM-120		FBM-200	
		HP	Amps	HP	Amps	HP	Amps	HP	Amps	HP	Amps
Mixing Motor	3	3	6.2	4	8.4	7	14.7	13	27.3	18	37.7
RPM Min/Max		136/280		135/272		122/246		113/225		105/120	
Bowl Motor	3	1	2	1	2	1.5	3.1	2	4.2	3	6.28
RPM Min/Max		25?		20?		18?		15?		13?	